

# Vinnsla steinefna til vegagerðar

Handbók fyrir vegagerðarmenn

Hafdís Eygló Jónsdóttir  
Gunnar Bjarnason

# Forsaga



- Verkefnið byrjaði upphaflega árið 2008
- Ýtarleg lokaskýrsla kom út árið 2013
  - *Vinnsla steinefna til vegagerðar. Tækjabúnaður, verktækni og framleiðslueftirlit*
- Ákveðið að gefa skýrsluna út sem handbók í A5 broti
- Unnið að endurbótum
- Útgáfa handbókar í lok febrúar 2015
  - Samskonar uppbygging og var á handbókinni:
    - *Sprengt berg í vegagerð – handbók fyrir vegagerðarmenn*
- Annað sem tengist verkefninu:
  - Heimsókn til Metso í Noregi, námskeið hjá Metso í Finnlandi 2011, Bauma sýning 2013, Hillhead sýning 2014

# Uppbygging



- Inngangur
- Tækjabúnaður og verktækni
  - Matari
  - Brjótur
    - Kjaftbrjótur
    - Kónbrjótur
    - Kastbrjótur
  - Færibönd
  - Hörpur
    - Helstu gerðir af hörpum
      - Hristihörpur
  - Þvottur á steinefnum
    - Þvottahörpur
    - Þvottakar með spöðum
    - Þvottakar með snigli fyrir sand
    - Þvottakar með snigli fyrir gróft efni
    - Þvottakar með skófluhjóli
    - Þvottatromlur
  - Aðskilnaður og rýrnun steinefna
  - Uppröðun tækjabúnaðar
- Framleiðslueftirlit
- Framleiðsla ólíkra efnisgerða
- Lokaorð

# Tækjabúnaður



Fastar einingar  
-steyptur grunnur, boltaðar niður



Færanlegar einingar  
-á sleðum

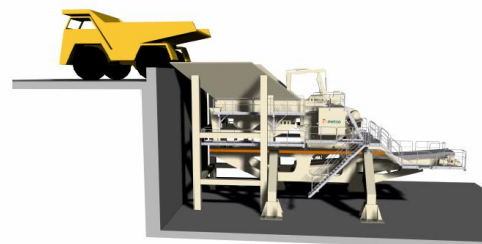

Flytjanlegar einingar  
-á hjólum



Sjálfkeyrandi einingar  
-á beltum



# Tækjabúnaður – brjótar



## Kjaftbrjótur

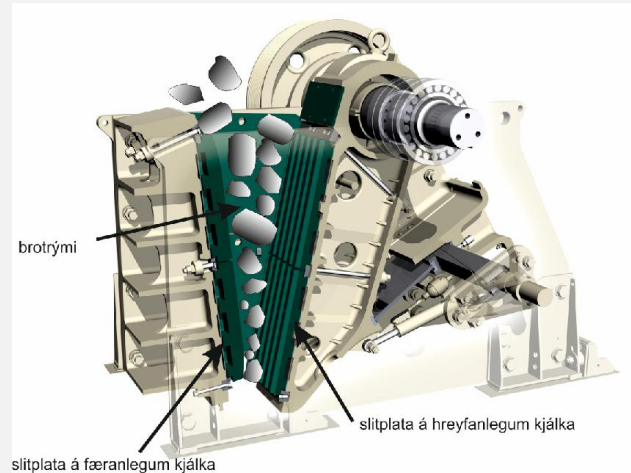

## Kónbrjótur

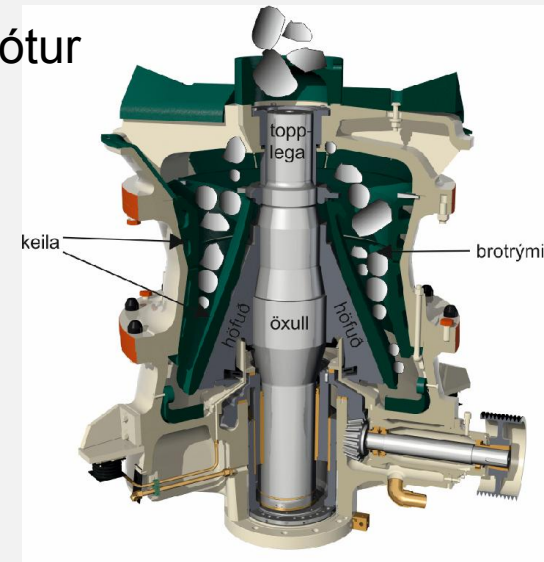

## Láréttur hverfibrjótur

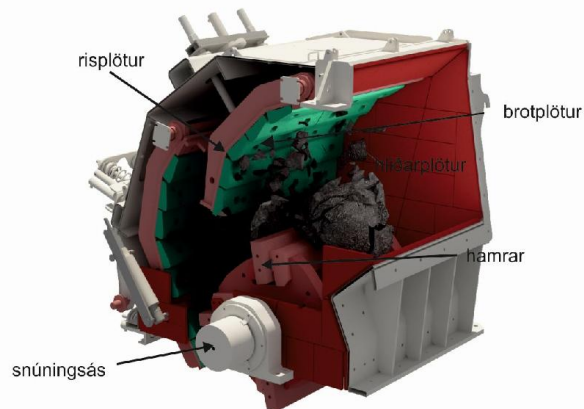

## Lóðréttur hverfibrjótur

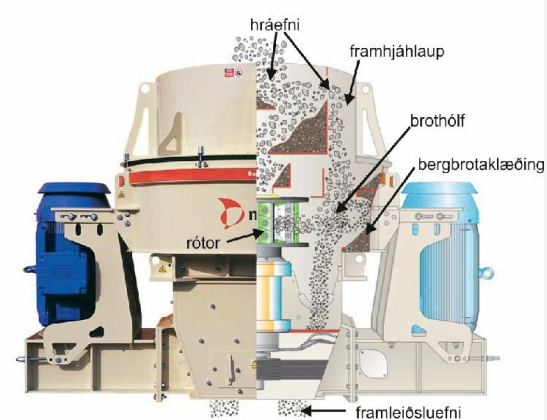

# Tækjabúnaður – brjótar

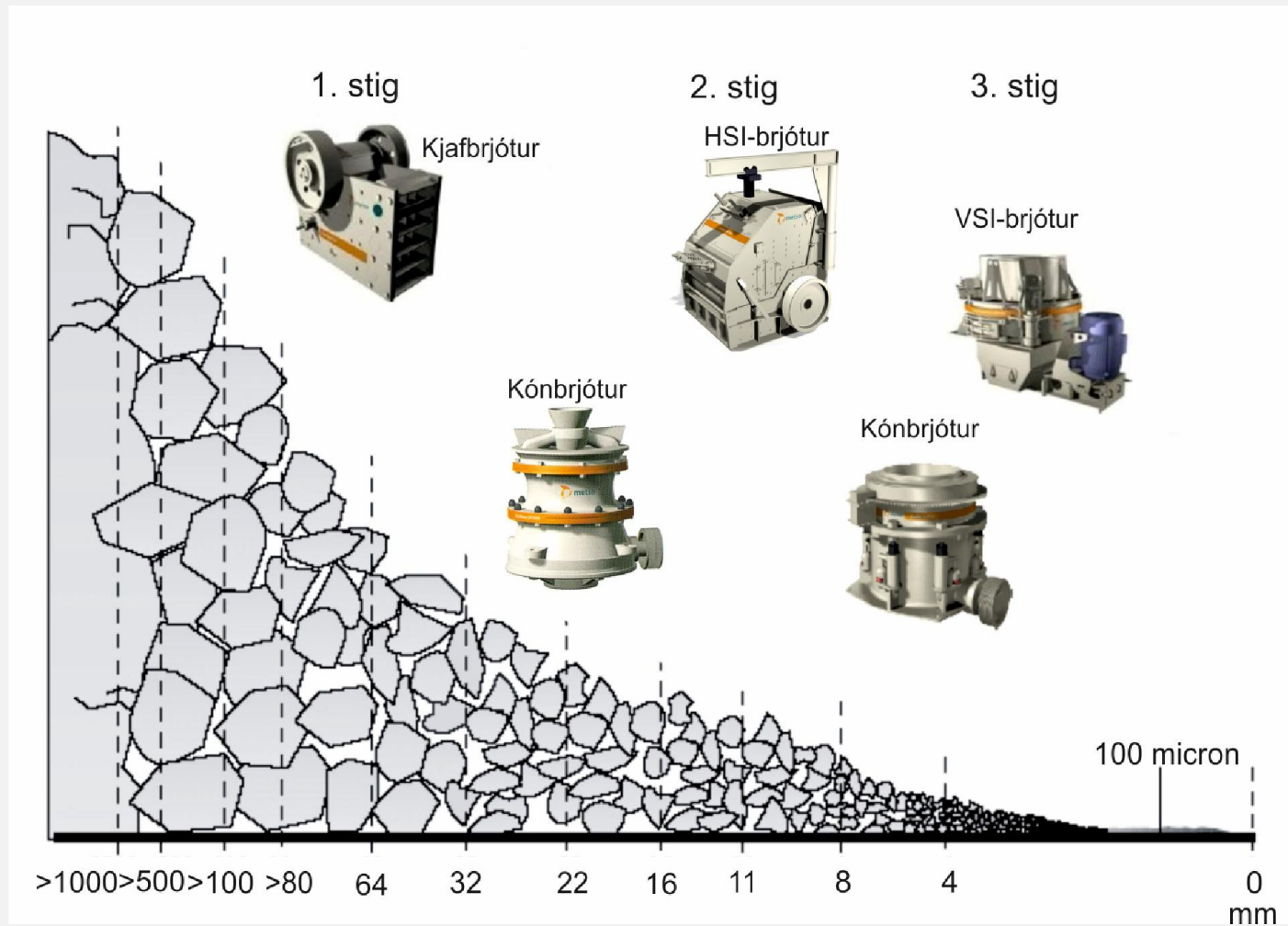

# Tækjabúnaður – hörpur



# Tækjabúnaður – hörpur





# Tækjabúnaður – þvottahörpur



# Tækjabúnaður – þvottahörpur



# Tækjabúnaður – hörpur – hörpunet

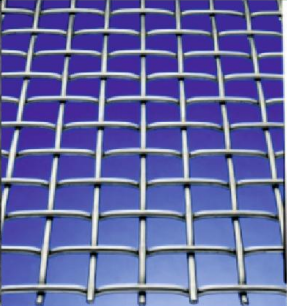
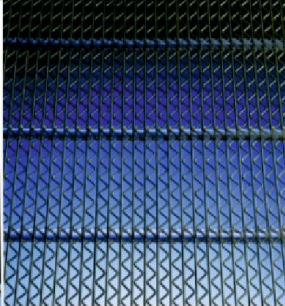
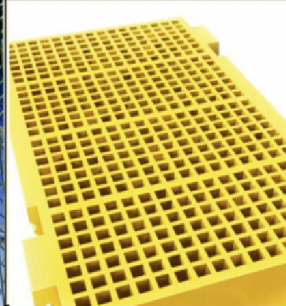
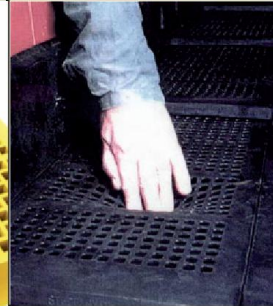

## Framleiðslustærð- og möskvastærð á möluðu efni

Framleiðslustærð mm	Möskvastærð ofin vírnet	Möskvastærð sikksakk net	Möskvastærð fyrir geriefni	
			Plastefni	Gúmmiefni
				
4	5	4,5	5,6	6,3
8	10	10	10,5	10,5
11,2	13,7	13	14,5	15,5
16	19	19	20	21
22,4	25	25	28	29
31,5	35,5	35,5	38	40
45	50		50	57
63	70		68	76

# Tækjabúnaður – hörpur – hörpunet – möskvar

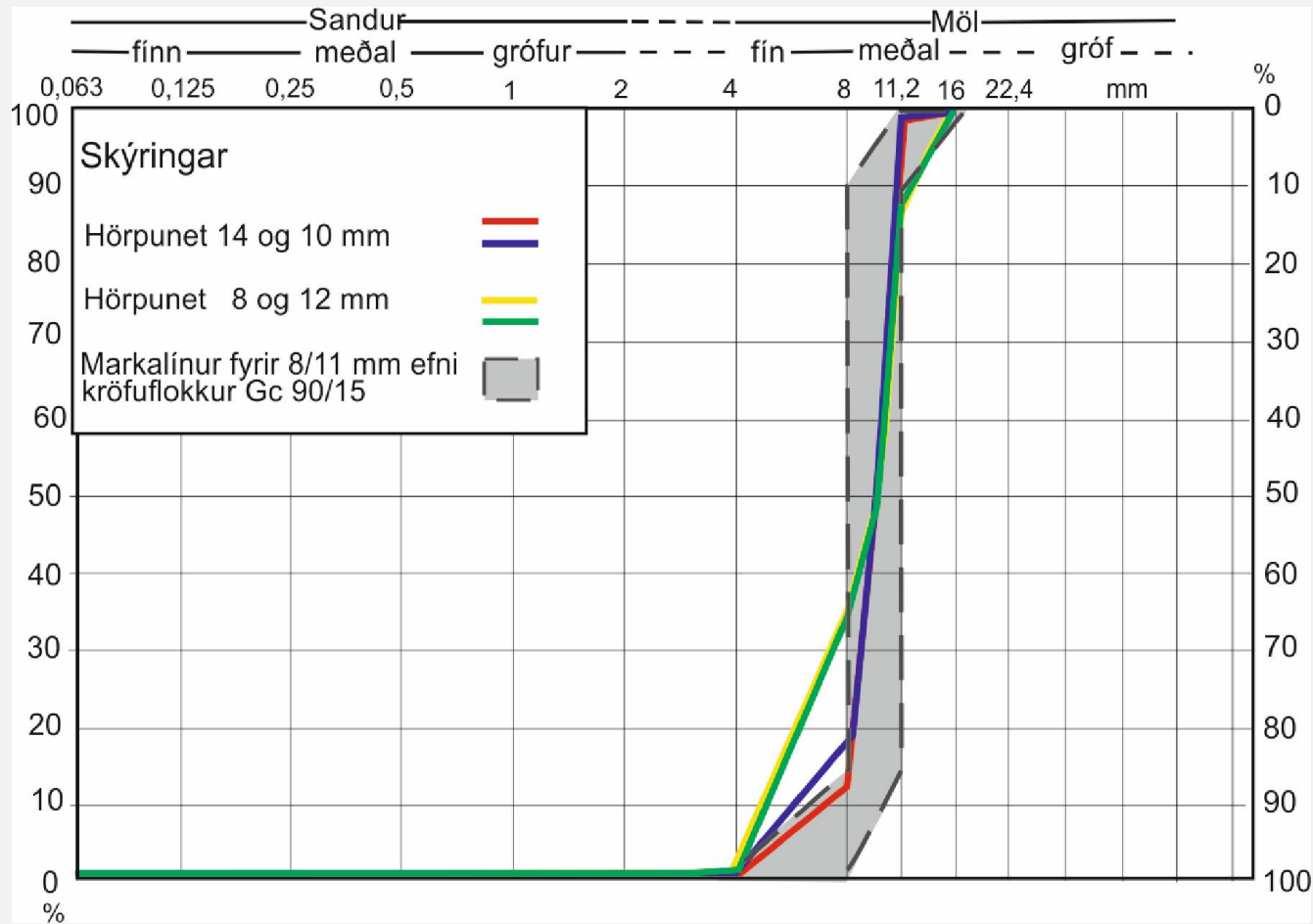

# Uppröðun tækjabúnaðar



A)

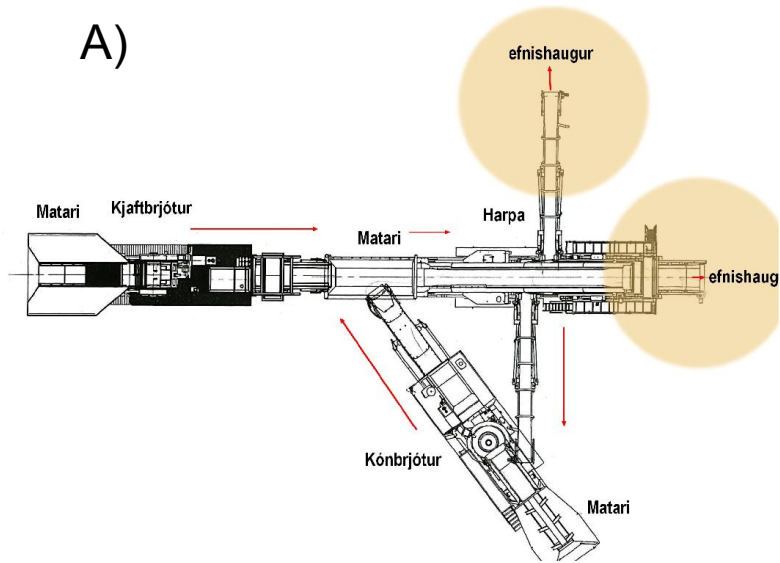

B)

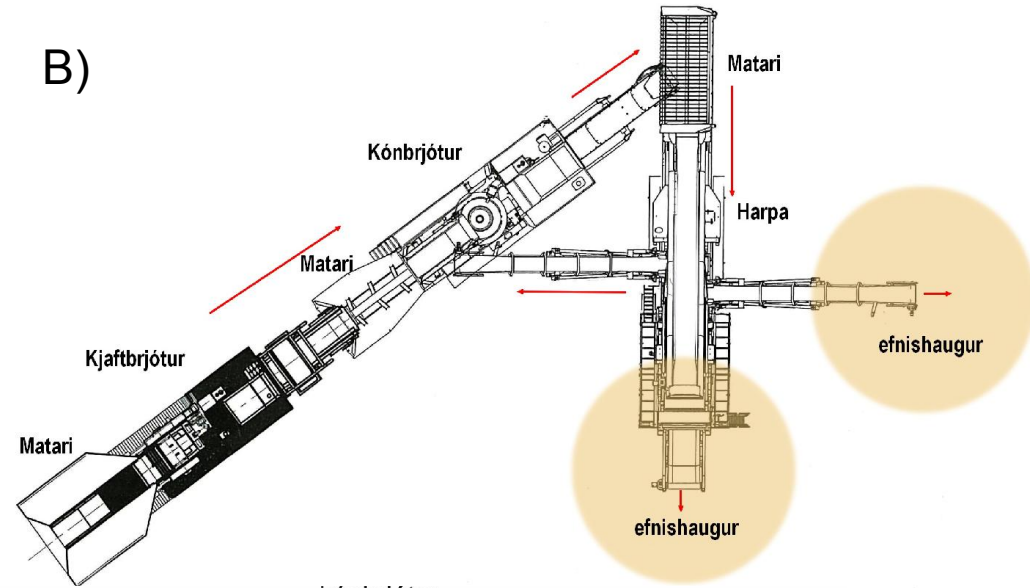

C)

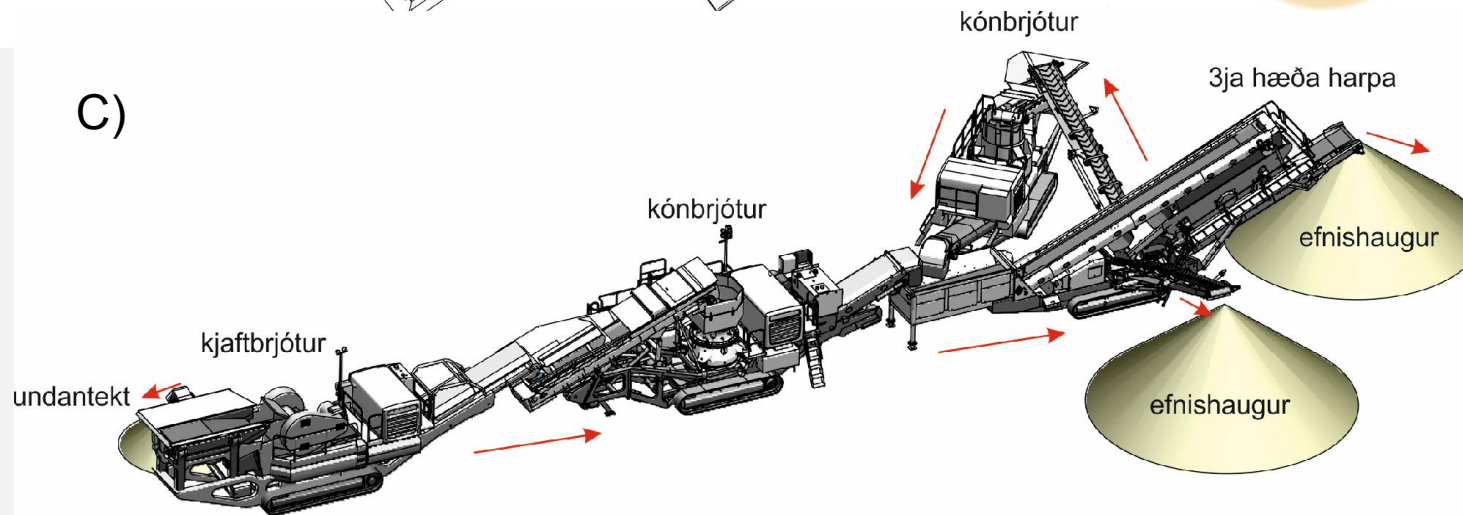

# Uppröðun tækjabúnaðar



# Uppröðun tækjabúnaðar – kleyfni



B+H+B

**29**



B+B+H

**16,1**



B+B+B+H

**6,9**



8/11 mm. Kúlnakvörn 5-6

## Uppröðun tækjabúnaðar – kleyfni



Kornastærð	Tvíbrotið B+H+B	Tvíbrotið B+B+H	Þríbrotið B+B+B+H	*Kleyfni stuðull
8/11 mm	29	16	6,9	Fl <sub>20</sub>
11/16 mm	14,1	8,5	4,3	Fl <sub>20</sub>

\*Miðað við ÁDU 1000-2000



# Takk fyrir

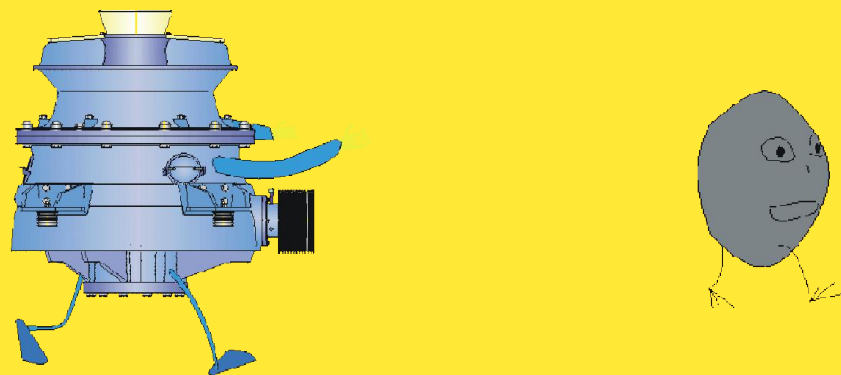

31.10.2014

